

① SCALE: 3/8" = 1'-0"

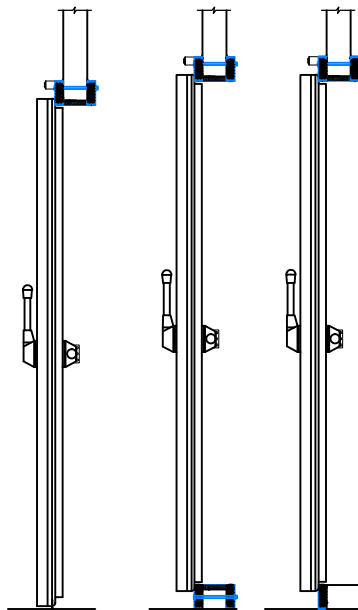

②

③

④

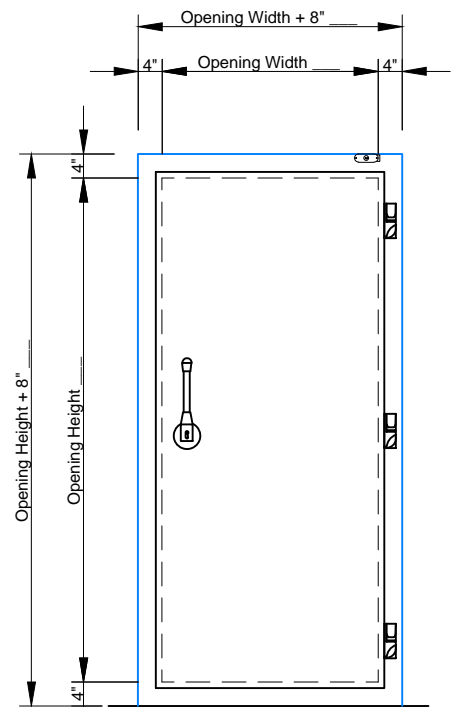

⑤ SCALE: 3/8" = 1'-0"

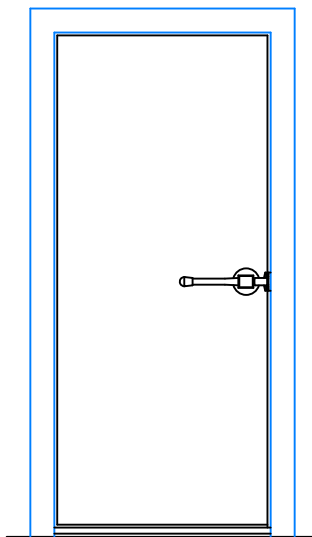

⑥ SCALE: 3/8" = 1'-0"

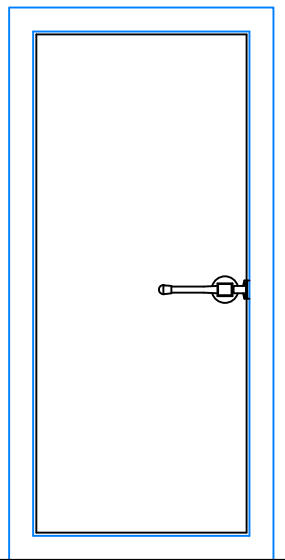

⑦ SCALE: 3/8" = 1'-0"

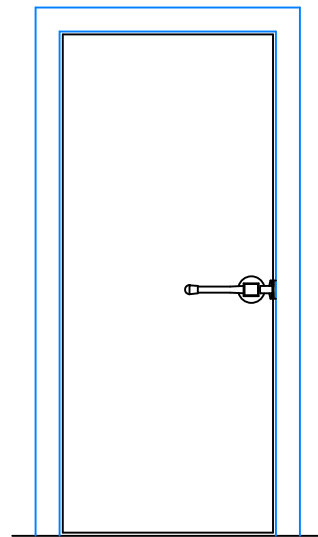

⑧ SCALE: 3/8" = 1'-0"

Energy Saver Door with 4" Backup Casings and Return Jambs

Model EFD-ESS-1

Bullet Hinges

Rotary Compression Latch

- ① ELEVATION – SWEEP BOTTOM SWING DOOR (EXTERIOR)
- ② SECTION – SWEEP BOTTOM SWING DOOR
- ③ SECTION – HIGH SILL WITH STEP OVER
- ④ SECTION – HIGH SILL
- ⑤ ELEVATION – HIGH SILL SWING DOOR (EXTERIOR)
- ⑥ ELEVATION – SWEEP BOTTOM SWING DOOR (INTERIOR)
- ⑦ ELEVATION – HIGH SILL WITH STEP OVER (INTERIOR)
- ⑧ ELEVATION – HIGH SILL (INTERIOR)

ALL DRAWINGS ARE 3/8" = 1'-0" SCALE UNLESS OTHERWISE NOTED



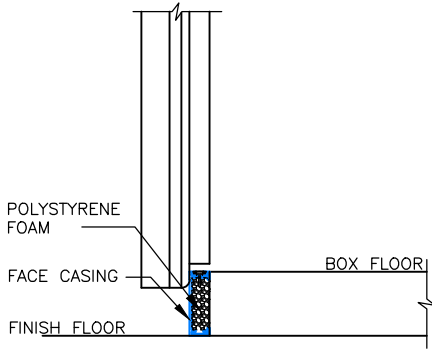

⑨ SCALE: 1" = 1'-0"

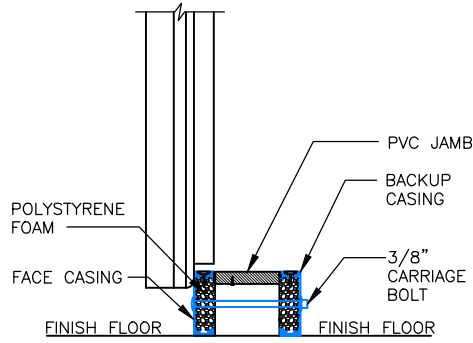

⑩ SCALE: 1" = 1'-0"

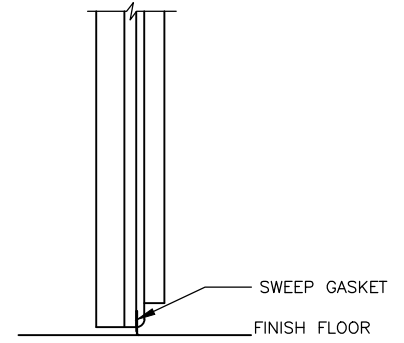

⑪ SCALE: 1" = 1'-0"

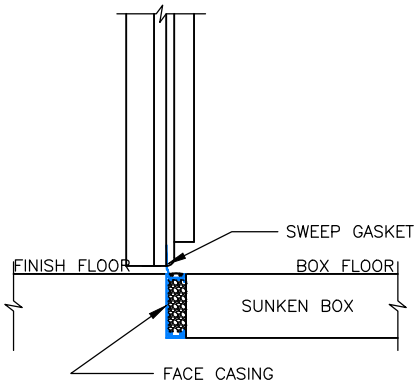

⑫ SCALE: 1" = 1'-0"

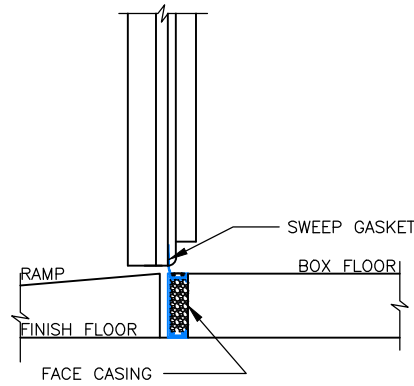

⑬ SCALE: 1" = 1'-0"

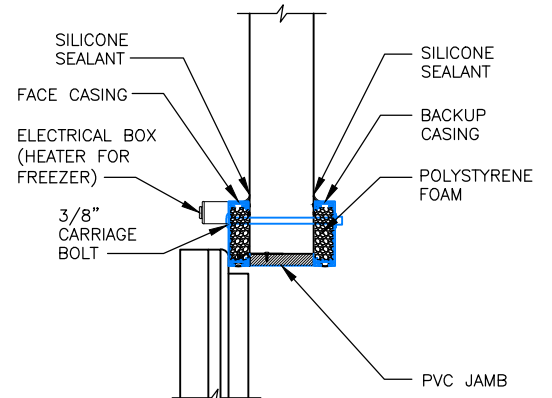

⑭ SCALE: 1" = 1'-0"

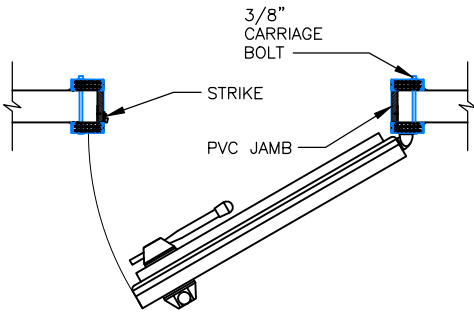

⑮ SCALE: 1/2" = 1'-0"

Energy Saver Door with 4" Backup Casings and Return Jambs

Model EFD-ESS-1

Bullet Hinges

Rotary Compression Latch

- ⑨ SILL DETAIL – HIGH SILL
- ⑩ SILL DETAIL – HIGH SILL WITH STEP OVER
- ⑪ SILL DETAIL – SWEEP BOTTOM
- ⑫ SILL DETAIL – HIGH SILL WITH SUNKEN BOX FLOOR
- ⑬ SILL DETAIL – HIGH SILL WITH REMOVABLE RAMP
- ⑭ HEAD – SWING DOOR – INSULATED METAL PANEL
- ⑮ JAMB – SWING DOOR – INSULATED METAL PANEL

